

2

1

B

B

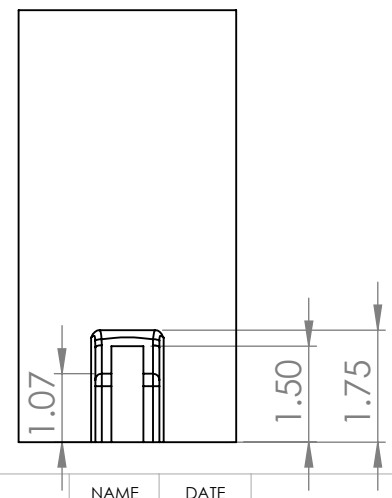
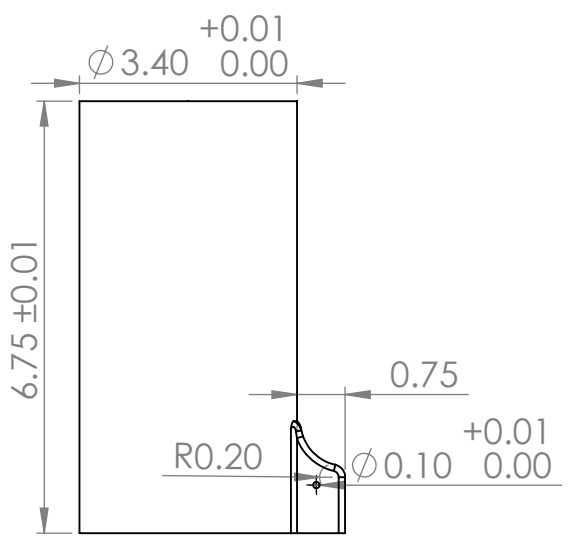
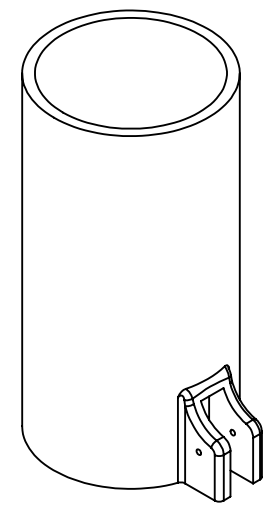
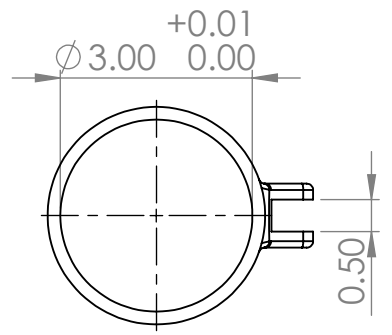

A

A

**PROPRIETARY AND CONFIDENTIAL**  
 THE INFORMATION CONTAINED IN THIS DRAWING IS THE SOLE PROPERTY OF <INSERT COMPANY NAME HERE>. ANY REPRODUCTION IN PART OR AS A WHOLE WITHOUT THE WRITTEN PERMISSION OF <INSERT COMPANY NAME HERE> IS PROHIBITED.

		UNLESS OTHERWISE SPECIFIED:	NAME	DATE
		DIMENSIONS ARE IN INCHES	DRAWN	
		TOLERANCES:	CHECKED	
		FRACTIONAL $\pm .02$	ENG APPR.	
		ANGULAR: MACH $\pm .01$ BEND $\pm 0.01$	MFG APPR.	
		TWO PLACE DECIMAL $\pm$	Q.A.	
		THREE PLACE DECIMAL $\pm$	COMMENTS:	
		INTERPRET GEOMETRIC TOLERANCING PER:	All Fillets not noted have a value of .01 in. $\pm .001$	
		MATERIAL	SIZE	DWG. NO.
		Clear Thermoset Plastic	<b>A</b>	outside cylinder
		FINISH	SCALE: 1:5	WEIGHT:
NEXT ASSY	USED ON	DO NOT SCALE DRAWING	REV	
APPLICATION			SHEET 1 OF 1	

TITLE:

SIZE **A** DWG. NO. outside cylinder REV

SCALE: 1:5 WEIGHT: SHEET 1 OF 1

2

1